



- Standard Analog phone or IP/SIP Phone
- Aluminum alloy die-casting body
- Vandal resistant handset and armored cord
- Weather resistant : IP66 to IP67
- Programmable for auto-dial
- Wall mounting, simple installation
- The phone will ringing loudly and lamp will flashing when there is a incoming call.
- With auto-answer feature after 5ringings,Auto- release the line when the other side cut off the line.
- With built-in amplifier, with external ringer and lamp: 15W (30W optional)
- AC/DC powered, RJ45 Port for SIP connection
- CE, FCC, RoHS, ISO9001 compliant

The JR100 series telephones are fully contained within a corrosion resistant cast aluminium weatherproof case with a door providing complete protection against dust and moisture ingress, resulting in a highly reliable product with a long MTBF.

The unique robust handset is manufactured from moulded Bulk Molding Compound and designed specifically to withstand arduous use in all environments, armoured cord to provide additional resistance to vandalism or heavy industrial use.

The JR100 series Weatherproof Telephones are designed for use by the railways/Subway/Highway tunnel, power stations, the armed services and heavy industry which require very reliable telephony under adverse conditions.

Standard Analogue

As a standard analogue telephone, this unit provides basic telephone functions and can be connected to any standard two-wire telephone line, including analogue PABX lines and PSTN.

SIP-VoIP TECHNICAL SPECIFICATIONS

Adapter Input:

100-240VAC 50~60Hz Output:5V/1A

Port:

WAN: 10/100Base- T RJ-45 for LAN, Auto MDIX

LAN: 10/100Base- T RJ-45 for PC, Auto MDIX

Power Consumption:

Idle:1.5W/ Active:1.8W

Voice Features

- Support 2 lines SIP, SIP 2.0 (RFC3261)
- Codec: G.711A/u, G.7231 high/low, G.729, G.722,G.726
- Echo cancellation: Support G.168 and hand-free can support 96ms
- Supports full duplex.
- SIP support SIP domain, SIP authentication(none, basic,MD5),DNS name of server, peer to peer
- SIP support 2 servers, user can through each server to calling in and out

Network Features

- WAN/LAN: support Bridge mode
- Support PPPoE for xDSL
- support VLAN
- Support Stun penetration
- Support DHCP get IP on WAN port

TECHNICAL SPECIFICATION

Casing Material

Die cast aluminium, epoxy powder coated.

Colors

Yellow, Orange, other colors to special order

Handset Material

Cycloy with stainless steel spiral cord

Keypad

No Keypad, Hot-line Type

Temperature

Operating: -40°C to +70°C

Storing: -45°C to +75°C

Weather Resistance

IP67

Ringtone

Shrill warble tone 110 dBA @ 1 metre typical

Hook switch

Electronic / magnetic with no visible moving parts

M.T.B.F.

Calculated to have an M.T.B.F. in excess of 50,000 hours using

Weight

Up to 7 kg depending on option

ANALOGUE

Dialing

MF (tone)

Power supply

Drawn from telephone line

Lightning / Transients

Protection to ITU-T k.21 enhanced levels

Programming

Can be programmed as an auto-dial phone by build-in keypad or remote programming

PACKAGE

Unit size: 339 * 146 * 126 (mm)

Carton size: 200*300*440 (mm)

Packaging materials: pearl cotton, carton

Gross weight: 7KG

Net weight: 6KG

DIMENSIONS:

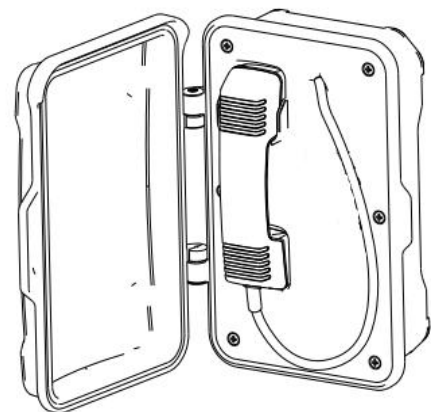
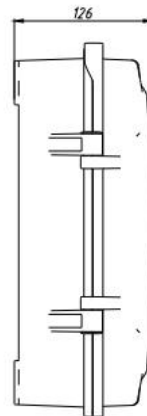
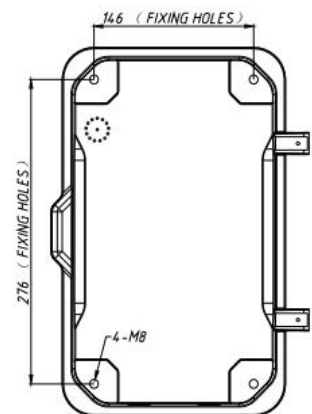
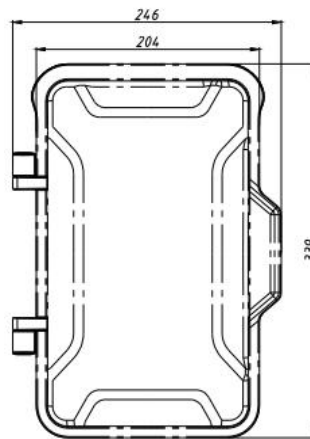

(Measured in mm)

APPROVALS



This mark indicates compliance with the:
Radio & Telecommunications Terminal Equipment Directive
2004/108/EC



This mark indicates compliance with the:
FCC Part 15 Subpart B Class B